

NEW DEVELOPMENTS IN BLOWN FLAP NOISE TECHNOLOGY

By John S. Gibson
Lockheed-Georgia Company
Marietta, Georgia 30063, USA

Abstract

There is considerable effort underway in the development of blown-flap powered-lift systems of the lower surface blowing (LSB) and upper surface blowing (USB) types. Proposed community noise criteria, for powered-lift aircraft using these systems, require that they be quieter than today's transports. The noise technology relating to blown-flap systems is reviewed in this paper. There are three general sources of noise: turbo-machinery, airframe, and the interaction noise of the jet blowing on the flaps. The latter noise-source area is the most critical and the main subject discussed here. Characteristics of LSB and USB systems are described, including noise spectra, directivity, jet velocity characteristics, aircraft geometric variation effects, and aircraft forward speed effects. Noise reduction concepts are described, including slowing down the jet flow field by devices and engine cycle modifications, structural geometry and shielding modifications, local flow field modifications of the passive and active type, and the absorption of noise. It is concluded that, while there has been considerable progress in the past several years, we still have much to learn, and that low noise characteristics in blown flap aircraft must be largely "built in" by better application of low noise principles during the design.

Introduction

In the past few years, several attempts have been made to define noise criteria for future STOL or short-haul aircraft, including studies by several government and industry groups. These efforts have resulted in numerous proposed schemes of aircraft noise criteria, such as not exceeding a 95 EPNdB limit on a 500-foot (152.4 m) sideline or not exceeding a one-square-mile 90 EPNdB footprint on the ground.

One U.S. Government Activity which put forth some noise criteria numbers similar in magnitude to those just mentioned, but in terms of the existing U.S. (FAR 36) and International (ICAO ANNEX 16) noise requirements, was the NASA/FAA Civil Aeronautics Research and Development (CARD) study in 1971⁽¹⁾. This study proposed noise levels by 1981 for all new-type transport aircraft ranging from 10 to 20 EPNdB below the current limits, as shown in Figure 1. For the expected first generation of turbofan powered-lift STOL transports, the proposed noise criteria range from 79 EPNdB to about 85 EPNdB at the FAR 36 measuring points. These criteria numbers were proposed on the assumption that new near-city-center "STOL Ports" would be in operation

by 1981. However, due to economic, energy, and environmental problems, it appears that the first turbofan short haul transports will operate from conventional existing airports for some time to come. Consequently, the definition of realistic and meaningful noise criteria continues to be an unresolved problem. In any case, it is generally believed that new powered-lift, short-haul aircraft will have to be considerably quieter than today's average transport to achieve public acceptance. To this end, several powered-lift technology programs are underway to better define the noise characteristics of these new types of turbofan aircraft, and to devise workable noise minimization and reduction methods for them.

The purpose of this paper is to review briefly some of the recent work on determining the unique noise source and system characteristics, and the development of noise reduction concepts for the two externally blown flap types of powered-lift system, which are usually referred to as the lower surface blown (LSB) and the upper surface blown (USB) systems.

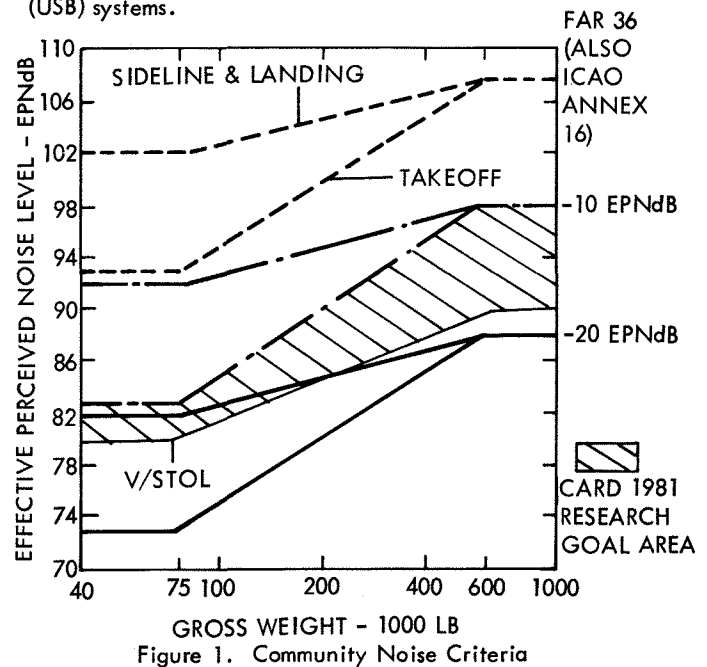

Figure 1. Community Noise Criteria

Noise Sources

Engine Noise

Sources of noise generated within the turbofan engine

are common to all aircraft. These include compressor and fan noise, turbine noise, and core engine noise (combustion and internal flow noise), as illustrated in Figure 2. Noise from the fan and primary jet flows, common to conventional turbofan aircraft, becomes highly modified and intensified in blown flap systems as described in the following two sections.

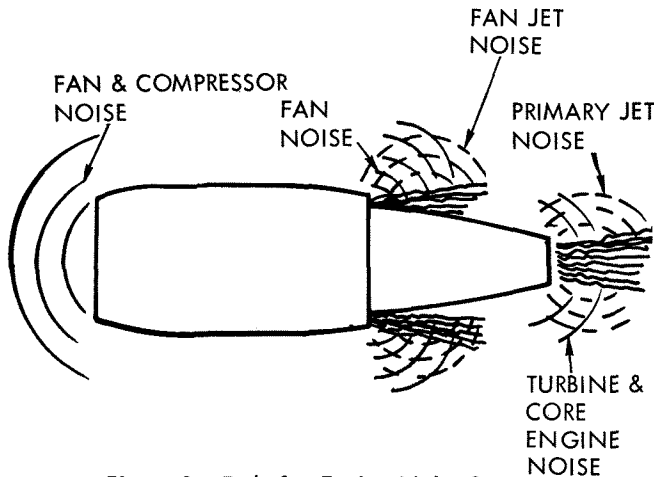

Figure 2. Turbofan Engine Noise Sources

LSB Jet Flow Field Noise

The jet flow field and possible noise source areas in an LSB system (2) are shown in Figure 3. Potential noise sources consist of several basic types: (a) jet impingement on wing and flap sections; (b) jet flow scrubbing over surfaces (small-scale turbulence scrubbing noise may not propagate from the surface but can be a flap structural vibration and sonic fatigue source); (c) whole-body fluctuating aerodynamic forces, particularly on individual flap segments; (d) jet flow leaving the several trailing edges; (e) jet flow mixing in the vicinity of the flaps, and in the wake (including the flow field edge vortex rollup); and (f) aero-acoustic resonances between various flow and structural elements of the system. Different source mechanisms may be more dominant than others, depending on the exact geometry and operation of the system. The first five sources are usually of a random, broad band nature, while the last is of the discrete-frequency or tone type.

These noise source areas are all related to one another and interact in most cases. For instance, consider noise caused by a bundle of turbulence from the jet impacting on a flap leading edge. This also causes (a) increased turbulence to stream along the flap surfaces, (b) increased turbulence in the jet flow separating from the trailing edge, (c) increased turbulence in the wake mixing region downstream of the trailing edge, and (d) depending on the size of the turbulence bundle, could cause whole-body fluctuating lift reactions. All of these effects can result in increased noise generation. In addition, if the turbulence bundles in the jet are produced periodically, there is a good chance of a periodic return of some energy from the impingement point to the origin of the turbulence bundle. This would complete a feedback loop and result in an aero-acoustic resonance which could produce tones or whistles in the system.

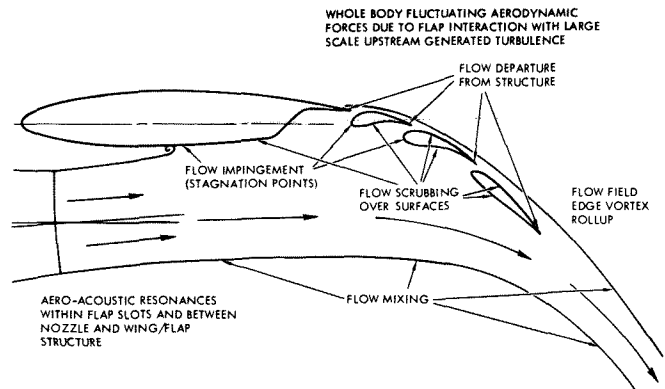

Figure 3. LSB Flow Field and Noise Sources

USB Jet Flow Field Noise

Flow field and potential noise source areas in USB systems are shown in Figure 4. The same basic source areas can exist here, although in modified form in some cases. In most USB systems, impingement does not exist (it does exist in cases of downward-vectoring nozzles from a pylon-mounted engine above the wing). Scrubbing and whole-body reactions do exist, but they are usually less severe than for LSB due to the smoother inflow to the wing and flap. Trailing-edge flow separation and the resulting shear-layer turbulence are probably more severe than for LSB due to the non-moving or slow-moving ambient air on the bottom of the flap. In fact, trailing-edge shear-layer noise is believed to be the predominant source in USB systems (for example, see Reference 3 through 6). Recent advances in knowledge of basic shear layers⁽⁷⁾ are providing improved understanding of this important noise source. Jet mixing in the vicinity of the flaps and in the wake is basically similar to that of an LSB system. Aero-acoustics resonances can occur between any two instability points in the flow system, about which more will be said later. As in the case of LSB, several or all of the noise sources are related and usually interact with each other.

WHOLE BODY FLUCTUATING AERODYNAMIC FORCES
AERO ACOUSTIC RESONANCES BETWEEN NOZZLE
AND UNSTABLE FLOW AREAS ON STRUCTURE

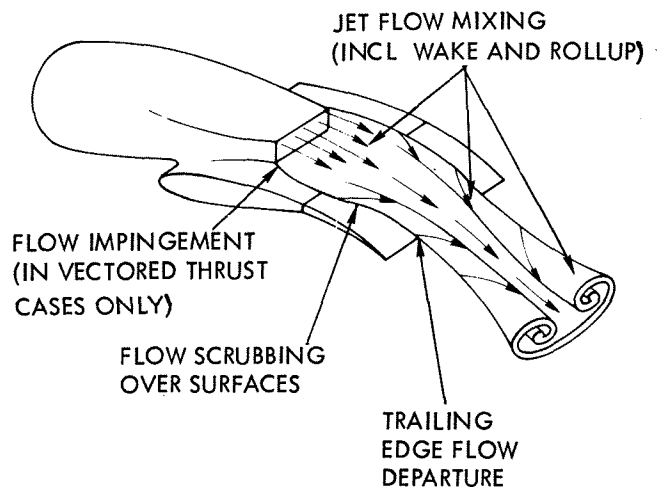

Figure 4. USB Flow Field and Noise Sources

Airframe Noise

An additional noise source area common to all aircraft is that caused by the airframe itself passing through the atmosphere. There are actually several source areas, of varying importance depending on exact geometric and operational details, as indicated in Figure 5(8). These sources are very similar to some of the blown flap sources, as indicated by a comparison of Figures 3 and 4 with Figure 5.

Noise-Field Characteristics

Some of the generalized characteristics discussed here are the authors' composites from several sources, including those found in References 2 through 6 and 9 through 27. These references do not represent an exhaustive list, as there is an extensive bibliography now on this subject, but they do represent some of the more recent work applicable to this discussion.

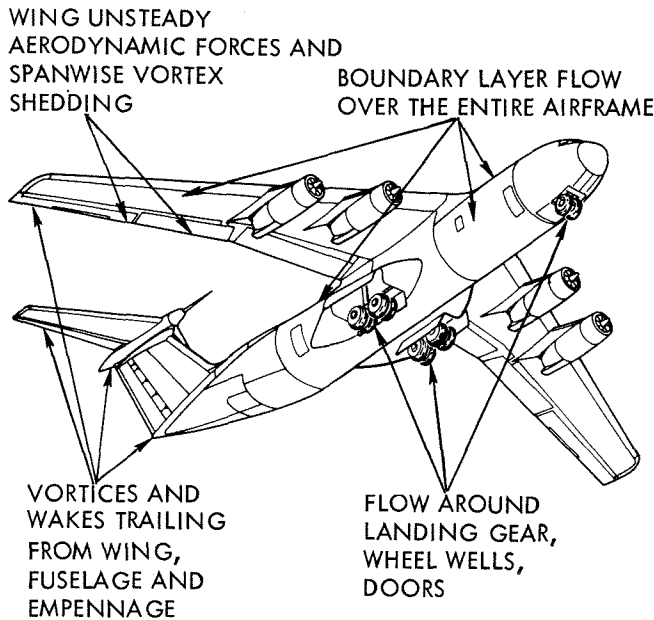

Figure 5. Airframe Noise Sources

Spectra

Generalized noise spectra for an observer under a static LSB and USB wing are shown in Figure 6. These spectra are for the same overall noise level for each system. The Strouhal number parameters are frequency (Hz), nozzle diameter or height, and nozzle exit velocity. This comparison shows the general similarity of spectrum shape with the LSB case being slightly greater, mainly in the high-frequency range. This occurs primarily because some of the high-frequency jet mixing type of noise, which is generated in the mixing layer above the wing for USB, is shielded by the wing from the observer. Just the opposite is true in the LSB case. Most experimental data actually have irregularities in the spectra, many of which are due to refraction and reflection from model structure and supports. Since these vary from one test set-up to another, they have been smoothed out in this illustrative example.

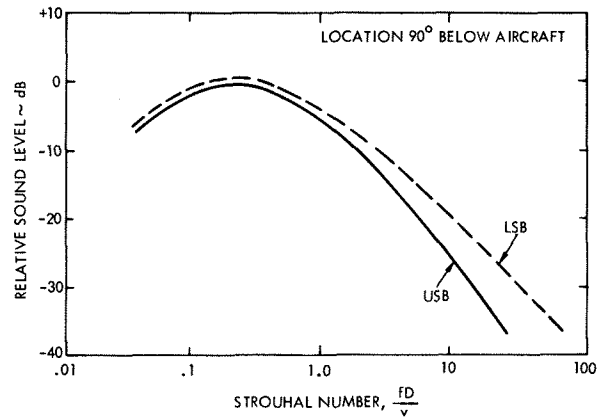

Figure 6. LSB and USB Noise Spectra

Directivity

Generalized directivity plots of overall noise levels in the vertical fore and aft plane are given in Figure 7. The 0° direction corresponds to the front of the aircraft, and the airflow arrow indicates the direction of the deflected engine exhaust stream for both LSB and USB systems. It is evident that in absolute terms the LSB system has inherently higher noise levels below the wing than does the USB system - for the same nozzle area and velocity. The differences in directivity for constant operating conditions are due to the shielding of USB mixing noise from below the wing (and vice versa for some of the LSB mixing noise from above the wing) and the fact that more turbulence and noise occur in the LSB system due to the flap slots and the high jet impingement angles.

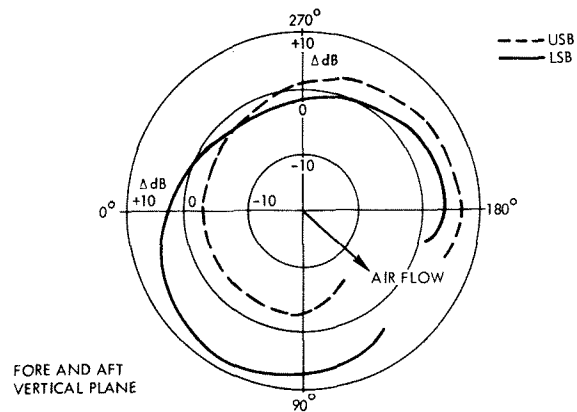

Figure 7. LSB and USB Overall Noise Directivities

Velocity Characteristics

The exhaust jet velocity is the major operating parameter affecting blown flap noise. It affects both LSB and USB noise in essentially the same manner as shown in Figure 8. This shows that, for a given nozzle, the overall noise level of either blown-flap system increases by about 18 dB with a factor of two velocity increase (the familiar sound power as a function of V^6 relationship of most flow-surface interaction noise sources).

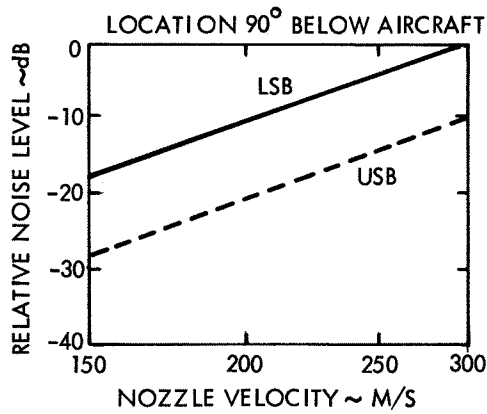

Figure 8. Blown Flap Noise as a Function of Exhaust Velocity

Geometric Effects

One of the obvious geometry changes that can occur in either system is flap angle. Figure 9 shows the effect for an LSB system (14). Even with retracted flaps, but with a small amount of jet flow interaction, noise increases occur over that of the jet alone. This is partially due to flow interaction and partially due to reflection of jet mixing noise from the wing. As the flap angle is progressively increased, noise levels progressively increase. This is due to the increasing turbulence with flap angle and the fact that the flow field is being turned more and more downward toward the observer. Similar effects are noted for USB cases, but the magnitudes are usually a little less.

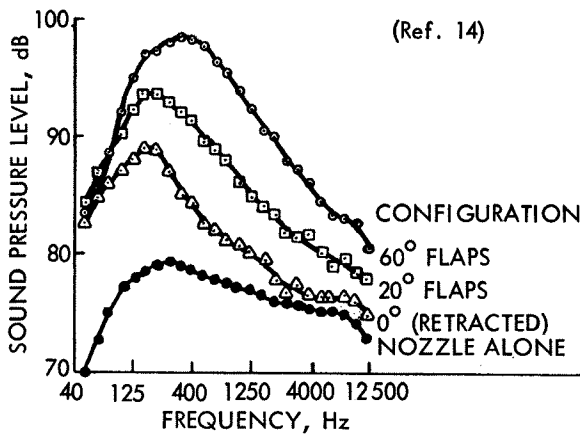

Figure 9. LSB Flap Angle Effect

Many other geometric variables affect noise spectra and or directivity. These include nozzle shape, nozzle impingement angle, nozzle location relative to the flaps, flap radius of curvature, and flap length. These affect noise to varying extents, but to review them all here would be unduly time-consuming, since so many variables are involved. Consequently, we will confine the remainder of

geometric effects discussion mainly to one part of an on-going program on USB noise (28). To show the type of work being done, let us use the investigation of nozzle impingement angle as an example. Figure 10 shows surface oil flow photographs looking down on a static USB model set-up. The pictures show the effect of 0° , 10° , 20° , and 30° nozzle impingement angles on the surface flow and spreading characteristics. At 0° , flow separation occurs prior to reaching the trailing edge. With flow attachment (10° and up) the flow spreads markedly with increasing nozzle angle. Notice the characteristic separated edges of the flow field (which roll up into the large inward rotating vortices) for the three cases with some flow attachment at the trailing edge. Also notice the characteristic inward flow along each side of the flow centerline (which rolls up into small outward rotating vortices). Figure 11, displays Schlieren photographs from the side of the wing for several nozzle angles (nozzle out of view to the left). Clearly evident are the turbulent flow field and the separation at 0° , corresponding to the same angle in the oil flow pictures. The total separation is less at 5° , and, as indicated in the oil flows, there is attachment over part of the trailing edge at 10° . The pictures look essentially the same for 10° and greater impingement angles. In addition to these flow visualizations, mean velocity and turbulence data (including correlations) were obtained at the trailing edge and elsewhere for comparison with the corresponding noise data, to improve understanding of the noise source and the generating mechanisms.

Typical noise spectral data at one location (directly under the wing) is given in Figure 12. At 0° impingement angle (separated flow) the noise is relatively low, just a little higher at the peak than the jet alone with no wing at all. In this case, as was shown in the flow visualizations, there is no flow attachment anywhere along the trailing edge. When the nozzle angle is increased to 10° , flow turning and attachment do occur and the predominant trailing edge noise source and the turned down flow field cause noise increases for an observer below the wing. As the nozzle angle is further increased, flow spreads rapidly (see Figure 10) becomes thinner and mixes faster, thereby reducing the velocity at the trailing edge and consequently less trailing edge noise is generated.

One final note in geometric effects has to do with the aeroacoustic resonance phenomena discussed earlier. There are several types of these resonances, such as the feedback of jet impingement instability energy at the flaps to the nozzle exit plane instability in an LSB system (22). Another is the feedback of instability energy from a trailing edge to the nozzle exit plane instability. This is dramatically illustrated for certain configurations of flat flaps as shown in Figure 13(6). The upper part of the figure shows a shadowgraph of a non-resonance condition, where the shear layer appears rather random with only a hint of periodic structure. When the flap is extended to a critical length (flap length to nozzle height ratio of 6.85 at a jet velocity of Mach 0.9 in this particular case) the appearance of obvious large-scale periodic vortices in the lower shear layer are evident. Further, the beginning of

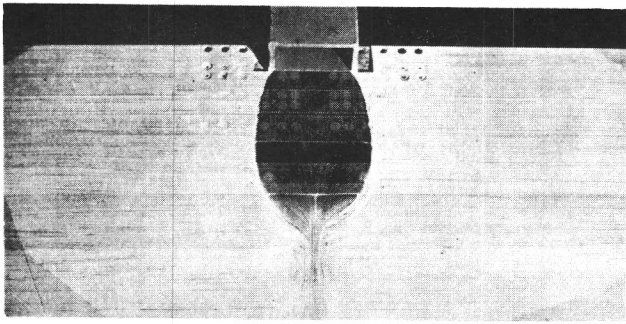

NOZZLE IMPINGEMENT ANGLE 0°

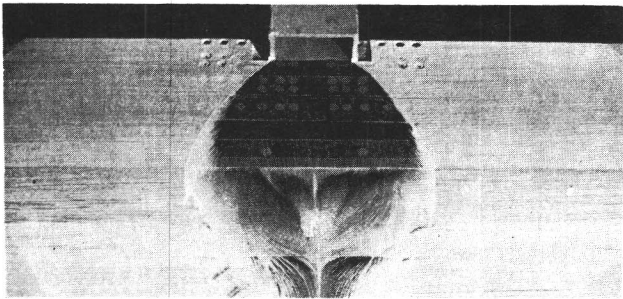

NOZZLE IMPINGEMENT ANGLE 10°

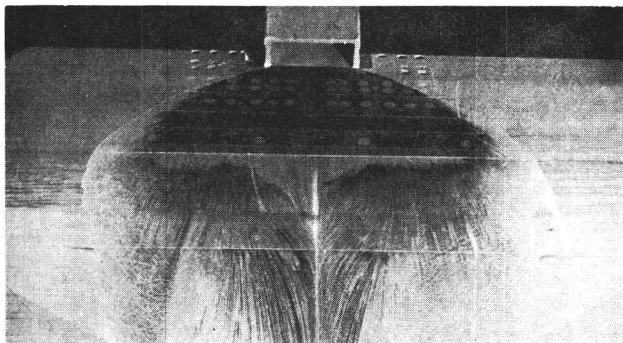

NOZZLE IMPINGEMENT ANGLE 20°

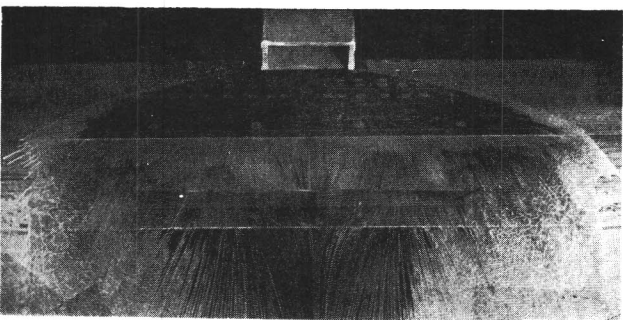

NOZZLE IMPINGEMENT ANGLE 30°

Figure 10. USB Surface Oil Flow Photographs

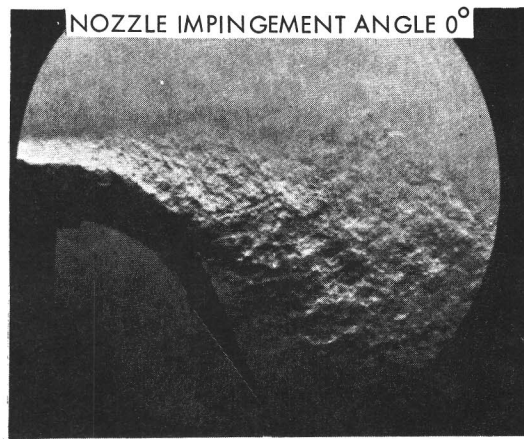

NOZZLE IMPINGEMENT ANGLE 0°

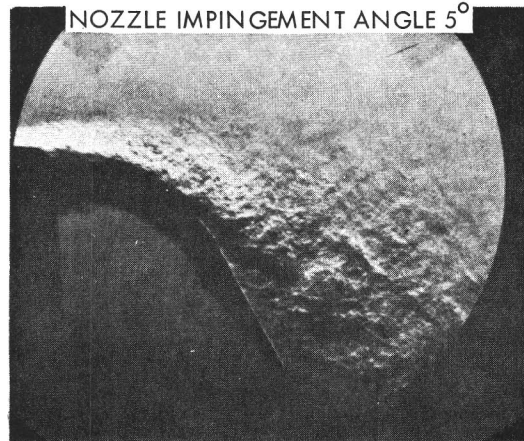

NOZZLE IMPINGEMENT ANGLE 5°

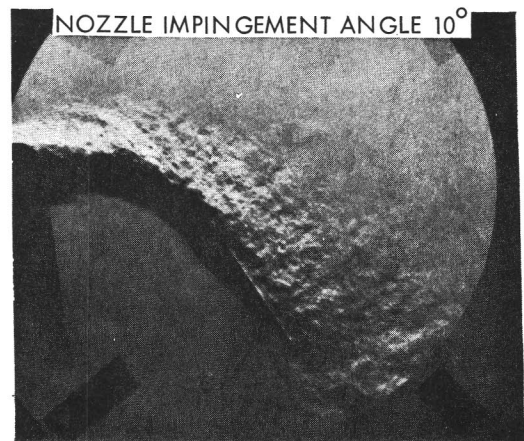

NOZZLE IMPINGEMENT ANGLE 10°



NOZZLE IMPINGEMENT ANGLE 20°

Figure 11. USB Turbulent Flow Schlieren Photographs

the vortex formation appears to be coming from the upper shear layer, above the flap, thus leading to the idea that some trailing-edge instability energy of aerodynamic or acoustic origin is completing a resonance loop with the instability at the upper side of the nozzle exit plane. The corresponding noise spectra for both cases are given in Figure 14. The short flap case has the broadband random appearance of typical blown flap noise which generally sounds like ordinary jet noise. The critical flap length case has pure-tone noise (fundamental and several harmonics) in addition to the broadband noise, as indicated in the lower half of Figure 14. These pure tones correspond to the periodic vortex shedding frequencies shown in the previous figure.

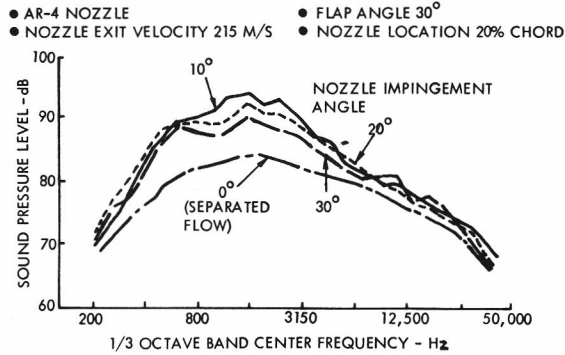
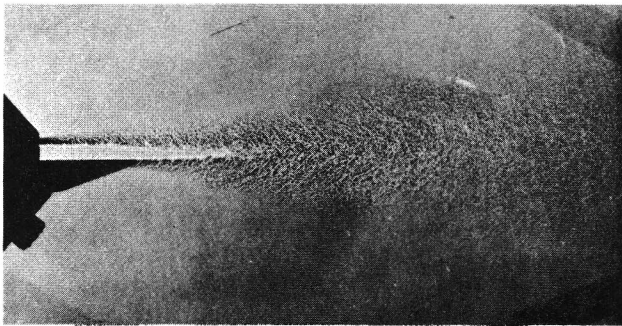
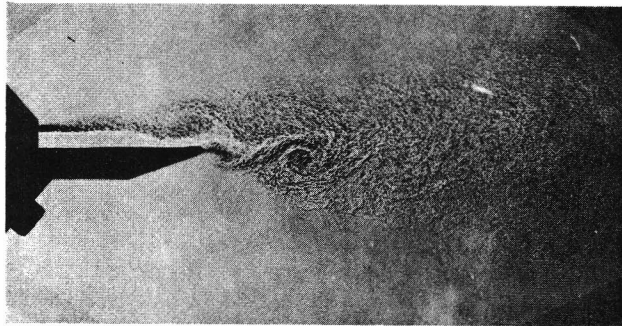

Figure 12. Effect of USB Nozzle Impingement Angle



FLAP LENGTH/NOZZLE HEIGHT = 3.97
(NON-RESONANCE) (Ref. 6)



FLAP LENGTH/NOZZLE HEIGHT = 6.85
(PERIODIC FLOW DISTURBANCES)

Figure 13. Shadowgraph Photographs of Periodic Flow Conditions

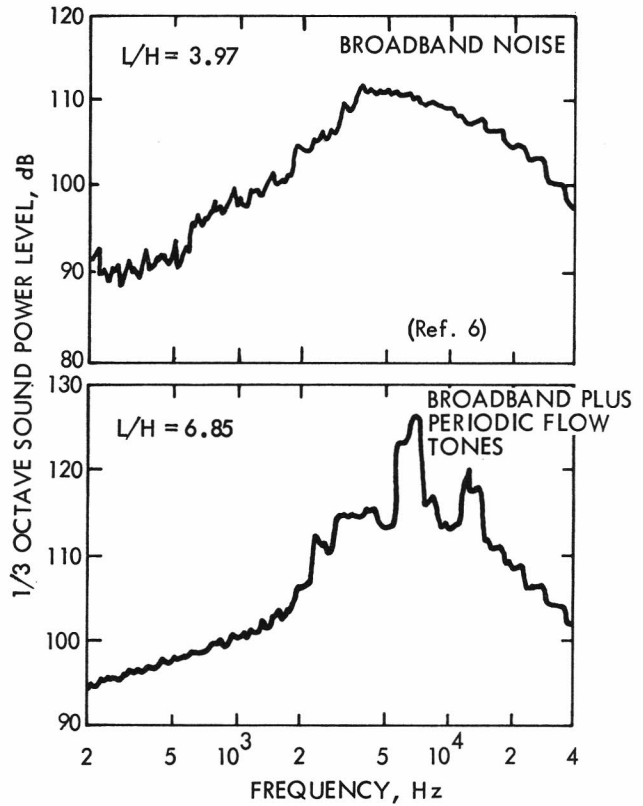

Figure 14. Noise Spectra of Periodic Flow Conditions

Forward Speed Effects

Recent experimental work has shown that aircraft forward speed does reduce noise directly under an LSB or USB type of aircraft. Data trends, generalized from several experimental projects conducted in wind tunnels (for example, see references 2, 12 and 23 through 27) are shown in Figure 15. The trends shown are for high-frequency noise (above the peak in the noise spectra) which corresponds to the maximum annoyance range on full-scale aircraft. Larger reductions are noted in many cases in the low-frequency range at model scale, which may be less important at full scale. The referenced programs and others reveal that forward speed effects at other angles in the vertical and horizontal planes vary from that shown, and in some cases result in noise increases. Some of these effects are due to directivity shifts due to noise field distortion, while others are functions of the changing turbulence-related noise sources.

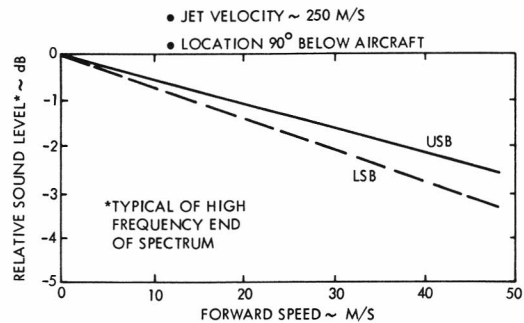

Figure 15. Forward Speed Effects

Noise Reduction

While the state of the art is advancing rapidly, there is still much to be learned about the nature of actual generating mechanisms in blown flap systems. Even though many of the details of the sources are not yet known, there are several ways to approach noise control. The first is to control basic jet flow characteristics by nozzle design or basic engine cycle changes. The second is to optimize the basic nozzle/wing/flap geometry or the aerodynamic design of the flap sections for lowest noise. The third is to locally modify the flow field, such as reducing turbulence at the trailing edges by secondary blowing, vortex generators, or trailing edge design. The fourth category is to absorb noise or turbulence energy by acoustically treated flap surfaces or ejector nozzle shrouds. All of these approaches attempt to reduce noise generation at the source, change the frequency of noise to a less sensitive frequency range, absorb noise energy, or change the directional characteristics of radiated noise to a less critical condition. There is also a fifth approach which is applicable to blown flap aircraft: increasing the distance between the aircraft and the community. Since powered-lift, short-haul aircraft will be capable of high takeoff and landing path angles, this approach will be more effective compared with conventional aircraft.

Since the first four approaches are similar in application to both LSB and USB systems and relate to noise reduction at or near the source, discussions of these approaches are presented below. As with the work described in the previous section, numerous investigative projects are completed and underway. Some of the generalizations have been drawn from several sources, including References 2 and 26 thru 33.

Jet Flow Modifications

As discussed previously, the jet flow velocity is of prime importance. The jet velocity of a given engine can be reduced by using mixer nozzle designs that increase the rates of jet mixing with the atmosphere (a technique further described in the section on absorption.) Care must be exercised, however, to be sure that the increased turbulence on the flaps due to increased mixing does not offset the mean velocity reduction effect. If the engine cycle itself is a variable in a new aircraft design, a fan bypass ratio or fan nozzle pressure ratio can be chosen that will result in a low fan jet velocity. Figure 16 shows a generalized curve of the change in perceived noise level (PNdB) for a blown flap type aircraft as a function of jet velocity for a constant amount of thrust. This curve is for a fixed distance from the aircraft. In actual practice, as the jet velocity is reduced by increasing the fan bypass ratio, the turbofan engine itself is growing larger and heavier. The larger weight and the increased drag due to the larger engine size will result in some loss of takeoff altitude for the same thrust. Thus, the aircraft would actually be a little closer to the ground observer and the full benefit of the reduced source noise would not be achieved. It is clearly evident that the effect on aircraft aerodynamic performance is a problem that must be taken into account in a complete aircraft noise reduction design study.

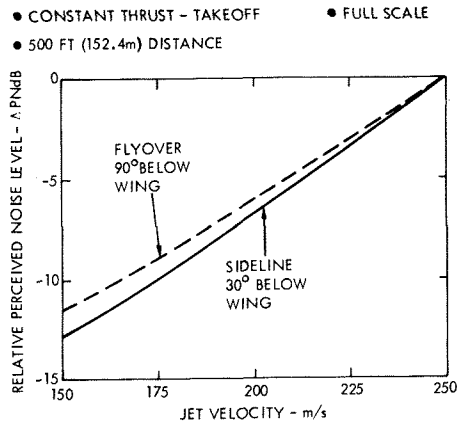

Figure 16. Engine Cycle Variation on Blown Flap Noise

Structural Geometry Modifications

In LSB systems, flap angles, nozzle-to-flap distances, number of flap slots, and associated features are variables that can be optimized for lowest noise, provided aircraft performance is not unduly compromised. In USB systems, characteristics such as nozzle impingement angle, location on the wing, and flap length and angle, are important parameters for low noise optimization of the blown-flap noise sources. In addition, the placement of the engine exhaust nozzle and the definition of flap angles and length are important from the internal engine noise standpoints. These sources (aft fan, turbine, core engine) can be partially shielded from the ground due to the wing and flap structure (Refs. 34, 35, 36). The exact structural geometry involved determines how much noise is diffracted around the wing and flap structure to the community below. A typical example of the shielding effect on aft fan noise is shown in Figure 17.

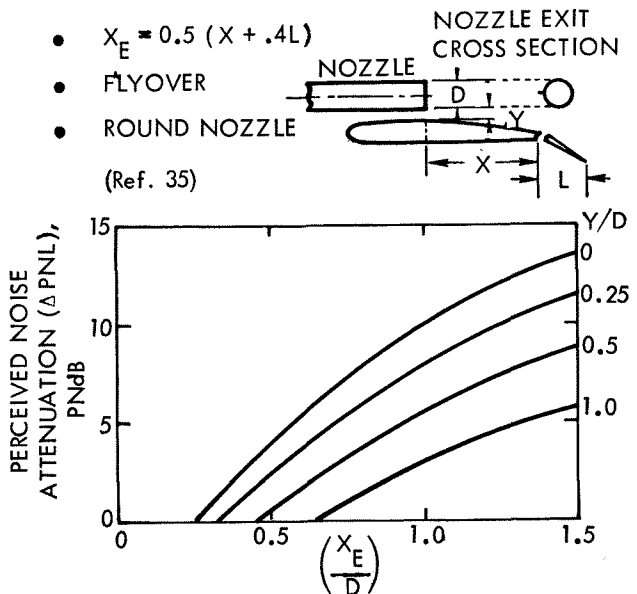

Figure 17. Fan Noise Shielding by a Wing

In general, with respect to either high-lift system, structural modifications that help to reduce mean velocities and/or turbulence levels on the structure (particularly trailing edges for USB) are beneficial and could reduce flap noise up to 3 to 4 PNdB without undue performance losses. Also, it has been found that elimination of perfectly

symmetrical flow field and geometric arrangements (such as skewing the trailing edge slightly with respect to the nozzle exit plane) usually reduces or eliminates aero-acoustic resonance effects. In USB systems, efforts should also be made to achieve maximum shielding benefits for internal engine noise.

Local Flow Field Modifications

These modifications are of two types, passive and active. The passive are structural in nature and consist of flap surface treatment with material to absorb turbulence energy, leading-edge treatment to reduce impacts and turbulence generation, and trailing-edge treatment to reduce turbulence amplification during flow separation. Such treatment materials are made of porous metal, perforated metals or plastics, and compliant materials such as rubber. Trailing edges can be made from some of these materials or of various irregular or serrated designs to ease shear-layer velocity gradients and turbulence generation. Several types of treatment used for trailing-edges (2,26) are shown in Figure 18. In other approaches, rows of small surface-mounted vortex generators have been installed to induce faster mixing and lower surface and trailing edge velocities, the surface has been roughened for the same reasons, or the flow has been made more random at the trailing edge.

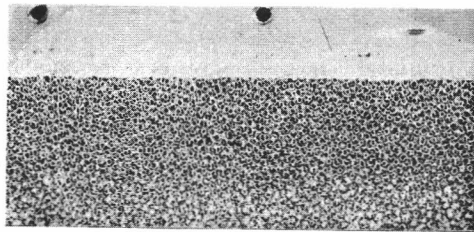

POROUS METAL

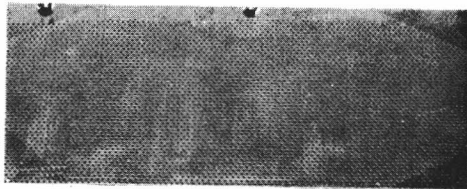

PERFORATED METAL

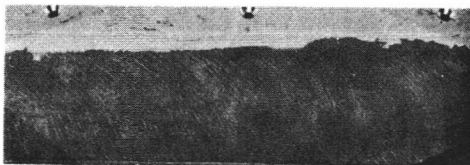

COMPLIANT (RUBBER)

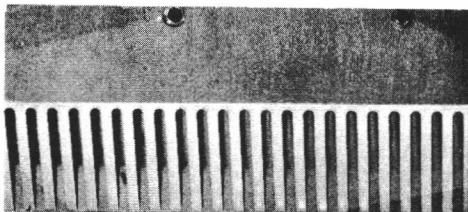

SERRATED

Figure 18. Typical Passive Trailing Edge Modifications

The active type of modification consists of the use of blowing or suction on the flaps for surface boundary layer or trailing-edge shear-layer control. One such experimental setup can be seen in Figure 19 for a triple-slotted LSB system (2,26). In this case, blowing air was introduced spanwise at the trailing edge of the third flap section through a plenum in the flap, fed by air pipes at the ends of the flaps as shown. Similar approaches have been tried for USB systems, where they are generally more effective since trailing edge noise is more predominant for USB. Various modifications have resulted in up to 2 to 3 PNdB reductions without seriously impacting aircraft performance.

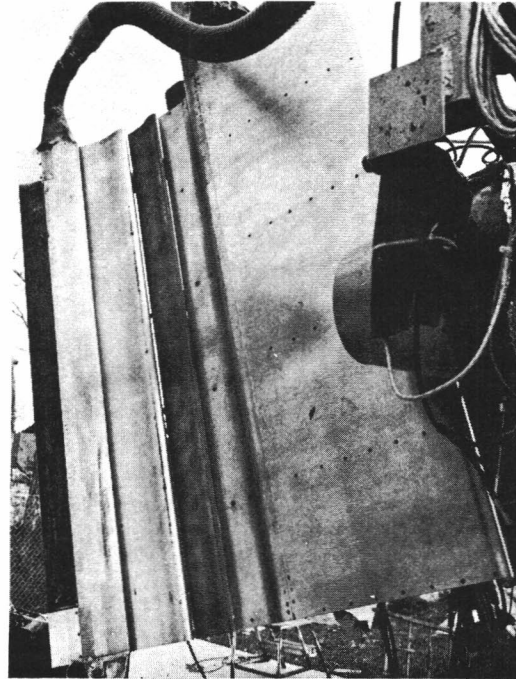

Figure 19. Trailing Edge Blowing on an LSB System

Absorption of Noise

The various forms of flap treatment for turbulence absorption or dissipation, discussed under the heading of Flow Field Modifications, also absorbs some noise and reduces noise reflection from the otherwise hard flap surfaces. The purely noise benefits may be small in this case compared with the turbulence reduction effects. Another concept where noise absorption is effective is in an acoustically lined or treated ejector shroud around the jet nozzle. Such a configuration, which is actually a combination absorber and mixer, is depicted in Figure 20 for an LSB test article (2,26). In this photograph, the viewer is looking at the back side of a triple-slotted flap system and is looking into the acoustically treated cylindrical ejector which is mounted around the exhaust plane of a multi-lobed engine nozzle. The multi-lobed nozzle by itself would create more high-frequency jet noise than an ordinary round nozzle. However, high-frequency jet noise is absorbed in the ejector lining (perforated metal, similar to that shown in Figure 18) and the combination of lobed nozzle mixing and ejector mixing slows the jet flow (30%) such that mid- and low-frequency jet mixing noise is reduced at the source, and flap impingement and trailing-edge velocities are lowered, thus also reducing blown-flap noise. The results of the test illustrated would reduce the noise of an LSB aircraft by 4

to 7 PNdB, with slight improvements in flap turning efficiency and thrust for takeoff. However, aircraft performance would deteriorate rapidly with increasing aircraft speed, and the ejector shroud would have to be stowed in cruise.

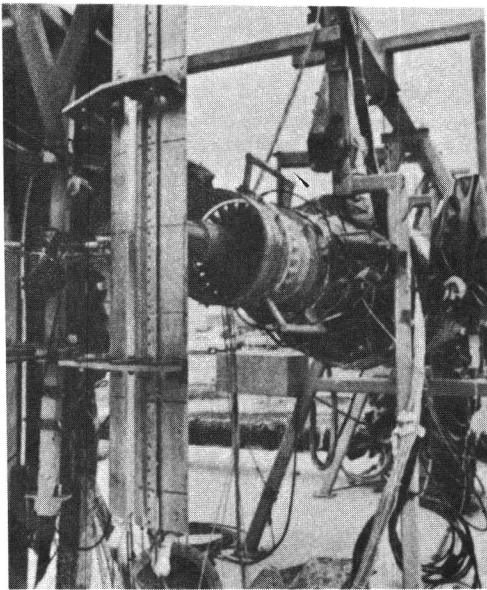

Figure 20. Acoustically Treated Ejector Shroud Installation

Concluding Remarks

There is currently some confusion and controversy regarding exactly which sources are most important, the mathematical representation of some sources, and practical noise reduction approaches. However, there are quite a few institutions, companies, and individuals at work on the various problems, and the overall technology field is improving rapidly. We have come a long way since the pioneering work of Maglieri and Hubbard⁽³⁷⁾ in 1958, but there is still much to learn. Continuing effort is needed on all the technical areas discussed to resolve current questions and to evolve a unified understanding of blown-flap noise phenomena.

It is obvious that built-in, low-noise design will require complete engine/air-frame compatibility and integration. During an aircraft design, the whole blown-flap system must be examined and evaluated simultaneously from the standpoints of aircraft performance, fuel economy, and noise to achieve a viable product. Today's economic, energy, and environmental conditions have resulted in the desire for aircraft that are slower, more saving of fuel, and quieter. Fortunately, efforts to realize each of these desires are headed in the same direction, and they tend to reinforce each other for the first time in aviation history.

References

1. Anon.; "Civil Aviation Research and Development Policy Study", DOT TST-10-5, NASA SP-266, March 1971.
2. Gibson, J. S.; "Noise Reduction of EBF Propulsive-Lift Systems", SAE Paper 750608, Air Transportation Meeting, Hartford, Conn., May 6-8, 1975.
3. Reddy, N. N. and Brown, W. H.; "Acoustic Characteristics of an Upper-Surface Blowing Concept of Powered-Lift System", AIAA Paper 75-204, 13th Aerospace Sciences Meeting, Pasadena, Calif., Jan. 20-22, 1975.
4. Reddy, N. N.; "Propulsive Lift Noise of an Upper Surface Blown Flap Configuration", AIAA Paper 75-740, 2nd Aero-Acoustics Conference, Hampton, VA., March 24-26, 1975.
5. Tam, C. K. W. and Yu, J. C.; "Trailing Edge Noise", AIAA Paper 75-489, 2nd Aero-Acoustics Conference, Hampton, Va., March 24-26, 1975.
6. Patterson, G. T., Joshi, M. C., and Maus, J. R.; "Experimental Investigation of the Aeroacoustic Characteristics of Model Slot Nozzles with Straight Flaps", AIAA Paper 75-471, 2nd Aero-Acoustic Conference, Hampton, Va., March 24-26, 1975.
7. Roshko, Anatol; "Structure of Turbulent Shear Flows: A New Look", The Dryden Lecture, AIAA Paper 76-78, 14th Aerospace Sciences Meeting, Washington, D. C., January 26-28, 1976.
8. Gibson, J. S.; "Recent Developments at the Ultimate Noise Barrier", Proceedings of the 9th Congress of the ICAS, Vol. 2, pages 741-751, Haifa, Israel, August 1974.
9. Fink, M. R.; "Experimental Evaluation of Theories for Trailing Edge and Incidence Fluctuation Noise", AIAA Journal, Vol. 13, No. 11, pp. 1472-1477, November 1975.
10. Hayden, R. E.; "Noise From Interaction of Flow with Rigid Surfaces: A Review of Current Status of Prediction Techniques", NASA CR-2126, NASA, Washington, D. C., October 1972.
11. Reddy, N. N. and Yu, J. C.; "Radiated Noise from an Externally Blown Flap", NASA TN D-7908, NASA, Washington, D. C., July 1975.
12. Preisser, J. S. and Fratello, David J.; "Acoustic Characteristics of a Large Upper-Surface Blown Configuration with Turbofan Engines", AIAA Paper 75-473, 2nd Aero-Acoustics Conference, Hampton, Va., March 24-26, 1975.
13. Heidelberg, L. J., Homyak, L., and Jones, W. L.; "Full-Scale Upper-Surface-Blown Flap Noise", SAE Paper 750609, National Air Transportation Meeting, Hartford, Conn., May 6-8, 1975.
14. Dorsch, R. G.; "Externally Blown Flap Noise Research", NASA TM X-71541, NASA Lewis Research Center, Cleveland, Ohio, May 1974.
15. von Glahn, U. and Groesbeck, D.; "Acoustics of Attached and Partially Attached Flow for Simplified OTW Configurations with 5:1 Slot Nozzle", NASA TM X-71807, NASA Lewis Research Center, Cleveland, Ohio, November 1975.

16. Fink, M. R.; "Prediction of Externally Blown Flap Noise and Turbomachinery Strut Noise", NASA CR-134883, NASA, Washington, D. C., August 1975.
17. Miles, J. H.; "Rational Function Representation of Flap Noise Spectra Including Correction for Reflection Effects", *Journal of Aircraft*, Vol. 12, No. 11, November 1975.
18. Searle, N.; "Acoustic Investigation of a Hybrid Propulsive Lift System", SAE Paper 74-WA/Aero-3, Winter Annual Meeting, New York, New York, November 17-22, 1974.
19. Foss, J. F. and Kleis, S. J.; "Vorticity and Acoustic Measurements in Vertically Impinging Jet Flows", Proceedings of the 3rd Interagency Symposium on University Research in Transportation Noise, pages 425-444, University of Utah, November 12-14, 1975.
20. Westley, R., Woolley, J. H., and Brosseau, P.; "Surface Pressure Fluctuations from Jet Impingement on an Inclined Flat Plate", AGARD - CP - 113 NAE/NRC of Canada, Ottawa, Canada, May 1973.
21. McKenzie, D. J. and Burns, R. J.; "Analysis of Noise Produced by Jet Impingement Near the Trailing Edge of a Flat and a Curved Plate", NASA TMX-3171, NASA, Washington, D. C., January 1975.
22. Neuwerth, G.; "Acoustic Feedback of a Subsonic and Supersonic Free Jet Which Impinges on a Foreign Body", Deutsche Luft-und Raumfahrt, DLR-FB 72-72, 1972. English translation NASA TT F-15719, NASA, Washington, D. C., 1974.
23. Bhat, W. V.; "Effect of Forward Speed on Jet Wing Flap Interaction Noise", AIAA Paper 75-475, 2nd Aero-Acoustics Conference, Hampton, Va. March 24-26, 1975.
24. Goodykoontz, J., von Glahn, U., and Dorsch, R.; "Forward Velocity Effects on Under-the-Wing Externally Blown Flap Noise", AIAA Paper 75-476, 2nd Aero-Acoustics Conference, Hampton, Va., March 24-26, 1975.
25. Falarski, M. D., Aoyagi, K., and Koenig, D. G.; "Acoustic Characteristics of a Large-Scale Wind-Tunnel Model of a USB Flap Transport Having Two Engines", NASA TM X-62319, NASA Ames, September 1973.
26. Pennock, A. P., Swift, G., and Marbert, J. A.; "Static and Wind Tunnel Model Tests for the Development of Externally Blown Flap Noise Reduction Techniques", NASA CR-134675, NASA, Washington, D. C., Feb. 1975.
27. Blankenship, G. L. and Oetting, R. B.; "Jet Impingement Noise Generation and Its Reduction Through Surface Acoustical Treatment", *Inter-noise 76 Proceedings*, P. 107-110, Washington, D. C., 5-7 April 1976.
28. NASA Contract NAS1-13870; "Noise Characteristics of Upper Surface Blown Flap Configurations", J. S. Gibson, Lockheed Program Manager, W. C. Sleeman, NASA Contract Monitor.
29. Pinkel, B. and Scharton, T. D.; "Reduction of Noise Generated by Fluid Flow Over a Plate", *Journal of the Acoustical Society of America*, Vol. 53, No. 4, 1973.
30. Hayden, R. E., Kadman, Y., and Chanaud, R. C.; "A Study of the Variable Impedance Surface Concept as a Means for Reducing Noise from Jet Interaction with Developed Lift-Augmenting Flaps", NASA CR-112166, NASA, Washington, D. C., July 1972.
31. Hayden, R. W., et al; "A Preliminary Evaluation of Noise Reduction Potential for the USB Flap", NASA CR-112246, NASA, Washington, D. C., 1972.
32. McKenzie, D. J. and Burns, R. J.; "Externally Blown Flap Trailing Edge Noise Reduction by Slot Blowing - A Preliminary Study", AIAA Paper 73-245, 11th Aerospace Sciences Meeting, Washington, D. C., January 10-12, 1973.
33. Bohn, A. J.; "Edge Noise Attenuation by Porous Edge Extensions", AIAA Paper 76-80, 14th Aerospace Sciences Meeting, Washington, D. C. January 27, 1976.
34. Hellstrom, G.; "Noise Shielding Aircraft Configurations: A Comparison Between Predicted and Experimental Results", Proceedings of the 9th Congress of the ICAS, Vol. 2, pages 730-740, Haifa, Israel, August 1974.
35. Conticelli, V. M., Di Blasi, A., and O'Keefe, J. V.; "Noise Shielding Effects for Engine-Over-Wing Installations", AIAA Paper 75-474, 2nd Aero-Acoustics Conference, Hampton, Va., March 24-26, 1975.
36. Jeffery, R. W. and Holbeche, T. A.; "An Experimental Investigation of Noise-Shielding Effects for a Delta-Wing Aircraft in Flight, Wind Tunnel, and Anechoic Room", AIAA Paper 75-513, 2nd Aero-Acoustics Conference, Hampton, Va., March 24-26, 1975.
37. Maglieri, D. J., and Hubbard, H. H.; "Preliminary Measurements of the Noise Characteristics of Some Jet-Augmented-Flap Configurations", NASA Langley Memorandum 12-4-58L, December 1958.